

**NEW**

# Four-quadrant fast response bi-polar power supply

Max. output voltage :  $\pm 5$  to  $\pm 300$  V

Max. output current :  $\pm 1$  to  $\pm 120$  A

Max. output power : 150 W to 2 kW

Broad bandwidth : DC to 30 kHz

## DOP series

**Available for expanding to 6 kW with master-slave connection**



# DOP series



DOP series is four-quadrant bi-polar power supply which source and sink electric power. They can be used in 2 modes of a constant voltage (CV) or a constant current (CC). The weight is half of the conventional units by adopting the aluminum frame. They are compact and high speed, driving output proportional to the input waveform such as a sine wave, triangular wave, saw wave, and square wave.

DOP series is most appropriate for inductive load including coil and transformer, capacitive load like capacitor, test of DC servo motor or automobile electric appliances, and surface treatment.

All the models are completely solid-state with output voltage between  $\pm 5$  V and  $\pm 300$  V.

Even faster models or the models with function generator are also available. Contact to local sales office for details.

## Applications

- Inductive load such as coil and transformer
- Capacitive load such as electric double-layer capacitor
- Voltage regulation tests for in-vehicle electrical component
- Evaluation test for solar panel related devices
- Various motor tests
- For surface treatment

This product is not designed for charge and discharge of battery. Please contact nearby sales if unit is used for charge and discharge application.

## Features

### Response speed

Newly developed DOP Series is the most appropriate for transient response test with such high power and broad bandwidth.

### Wide lineup

Select a model fitting for your applications from the lineup of various output voltage and current.

### DC bias

10-turn potentiometer to be used for the output setting volume when used as the DC power supply and for the bias setting when used as AC power supply is equipped.

### Silent operation

Operating noise became quiet by having employed the silent fan, and also it became easy-to-use.

### DC output meter

3-digit digital meter displays the DC value of the output voltage and current. (The option of rms indication is available.)

### Four-quadrant action

DOP Series can be used both as a high speed response DC power supply and as a DC electronic load.

### Constant voltage (CV) / Constant current (CC)

A single switch on the front panel selects between CV and CC modes.

### Compact & light weight

For maximum compactness and light weight, DOP Series has been improved for small footprint and easy carry.

### Complete protective function

Protective function against over voltage/current and protective measures against output short-circuit are completely provided.

### Master-slave

The option of Master-slave control will resolve power shortages.

# Lineup

\*Models with voltage, current or frequencies not listed here are also available. Please contact the nearest sales office.

Model	Output voltage (rms value)	Output current (rms value)	Output power	Frequency response (-3 dB)	Dimensions (⇒P.6 · P.7)	Weight kg (approx.)
DOP5-30	±5 V (3.5 V)	±30 A (21 A)	150 W	DC to 20 kHz	A	17
DOP5-60		±60 A (42 A)	300 W		B	23
DOP6-120	±6 V (4.2 V)	±120 A (84 A)	720 W	DC to 20 kHz	C (Busbar type)	47
DOP10-15	±10 V (7 V)	±15 A (10.5 A)	150 W	DC to 20 kHz	A	11
DOP10-30		±30 A (21 A)	300 W		A	17
DOP10-60		±60 A (42 A)	600 W		B	23
DOP20-7.5	±20 V (14 V)	±7.5 A (5.3 A)	150 W	DC to 20 kHz	A	11
DOP20-15		±15 A (10.5 A)	300 W		A	17
DOP20-30		±30 A (21 A)	600 W		A	23
DOP20-60		±60 A (42 A)	1200 W		C (Terminal board type)	40
DOP20-100		±100 A (70 A)	2000 W		C (Busbar type)	47
DOP25-6	±25 V (17.6 V)	±6 A (4.2 A)	150 W	DC to 30 kHz	A	11
DOP25-12		±12 A (8.6 A)	300 W	DC to 30 kHz	A	17
DOP25-24		±24 A (17.1 A)	600 W	DC to 30 kHz	A	23
DOP25-48		±48 A (34 A)	1200 W	DC to 20 kHz	C (Terminal board type)	40
DOP25-80		±80 A (56 A)	2000 W	DC to 20 kHz	C (Busbar type)	47
DOP30-40	±30 V (21 V)	±40 A (28.6 A)	1200 W	DC to 20 kHz	C (Terminal board type)	40
DOP45-3.3	±45 V (32 V)	±3.3 A (2.4 A)	150 W	DC to 20 kHz	A	12
DOP45-6.6		±6.6 A (4.7 A)	300 W		A	17
DOP45-13.3		±13.3 A (9.5 A)	600 W		A	23
DOP45-16		±16 A (11.3 A)	720 W		A	23
DOP45-26.7		±26.7 A (18.9 A)	1200 W		C (Terminal board type)	40
DOP45-44.4		±44.4 A (31.1 A)	2000 W		C (Terminal board type)	47
DOP60-2.5	±60 V (42 V)	±2.5 A (1.75 A)	150 W	DC to 20 kHz	A	12
DOP60-5		±5 A (3.5 A)	300 W		A	17
DOP60-10		±10 A (7 A)	600 W		A	23
DOP60-20		±20 A (14 A)	1200 W		C (Terminal board type)	40
DOP60-33.3		±33.3 A (23.3 A)	2000 W		C (Terminal board type)	47
DOP70-17	±70 V (49 V)	±17 A (12 A)	1200 W	DC to 20 kHz	C (Terminal board type)	40
DOP80-25	±80 V (56 V)	±25 A (18 A)	2000 W	DC to 20 kHz	C (Terminal board type)	47
DOP120-2.5	±120 V (84 V)	±2.5 A (1.75 A)	300 W	DC to 20 kHz	A	18
DOP120-5		±5 A (3.56 A)	600 W		D	30
DOP120-10		±10 A (7 A)	1200 W		C (Terminal board type)	45
DOP150-2	±150 V (105 V)	±2 A (1.4 A)	300 W	DC to 20 kHz	A	18
DOP150-4		±4 A (2.8 A)	600 W		D	30
DOP150-8		±8 A (5.6 A)	1200 W		C (Terminal board type)	45
DOP200-1.5	±200 V (141 V)	±1.5 A (1.05 A)	300 W	DC to 20 kHz	A	18
DOP200-1.75		±1.75 A (1.23 A)	350 W		A	18
DOP200-3		±3 A (2.1 A)	600 W		D	30
DOP200-3.5		±3.5 A (2.47 A)	700 W		C (Terminal board type)	38
DOP200-6		±6 A (4.2 A)	1200 W		C (Terminal board type)	45
DOP300-1	±300 V (210 V)	±1 A (0.7 A)	300 W	DC to 20 kHz	A	18
DOP300-2		±2 A (1.4 A)	600 W		D	30
DOP300-4		±4 A (2.8 A)	1200 W		C (Terminal board type)	45

# Specifications

## Input voltage/Input current

Target Model	Rated Input voltage (AC50 / 60 Hz)	Rated Input current	Recommended breaker
150 W model*1	AC100 to 120 V ±10% single phase	4 A	100 VAC / 15 A
DOP5-30 model		5 A	
300, 350 W model*2		7 A	
DOP5-60 model		10 A	
600 W model	AC200 to 240 V ±10% single phase	7 A	200 VAC / 15 A
700, 720 W model		8 A	
1.2 kW model		13 A	
2 kW model		20 A	

\*1. except DOP5-30 \*2. except DOP5-60

**External control voltage(Vcon-in)** -10 V to +10 V  
Input impedance is 10 kΩ or more.

**Output indication (DC value indication)** Output voltage : 3-digit digital meter ±999  
Output current : 3-digit digital meter ±999

**DC bias** 10-turn potentiometer enables setting between -100% and +100%.

**Ripple** Less than 0.02% rms

**Stability** 0.016% / H typ.

**Setting accuracy** ±0.5% Full scale

**Distortion factor** CV : 0.05% CC : 0.5% (Rated output and rated load)

**Regulation** Line : 0.05% (for ±10% input change)  
Load : 0.05% (for 10 to 100% load change)

**Temperature coefficient** 0.02% / °C

**Output monitor** Output voltage : -10 V to +10 V ±1% Full scale  
Output current : -10 V to +10 V ±1% Full scale  
Output impedance 1 kΩ

**Protections** Protection against output short-circuit, overvoltage, overcurrent  
Blackout protection (can be canceled with -LN option)  
Interlock

**Other functions** Remote switch (Output ON/OFF)  
(external relay or open collector)

Output	Relay	Open collector
ON	SHORT	$V_{CE} \leq 0.4 V$
OFF	OPEN	$V_{CE} \geq 2 V$

Sink Current 1 mA

**Operating temp.** 0°C to +40°C

**Storage temp.** -20°C to +70°C

**Humidity** 20% to 80% RH (no condensation)

**Accessories** Input cable ... 2.5 m (1)  
(3-pin connector for 100 to 120 V input model)  
Flying lead for 200 to 240 V input model)  
Instruction manual (1)

## Protections

### Over voltage protection (O.V.P)

DOP series is equipped with over voltage protection, which protects load by limiting voltage up to approx. 110% of the rated output voltage even at abnormal conditions.

\*-LVc option (output voltage limiter) enable to control the output in 0 to approx. 110% range.

### Over current protection (O.C.P)

DOP series is also equipped with over current protection, which protects power supplies and load by limiting current up to approx. 110% of the rated output current.

\*-LCc option (output current limiter) enable to control the output in 0 to approx. 110% range.

### High speed over current protection

DOP series is provided with 2 types of over current protections, high speed over current protection to limit the pulse current, and standard over current protection to limit the static current.

The standard over current protection limits the static current, responding at around 1ms. Additional high speed over current protection can limit pulse current of square waveforms or from capacitor at approx. 2 times more current of rating.

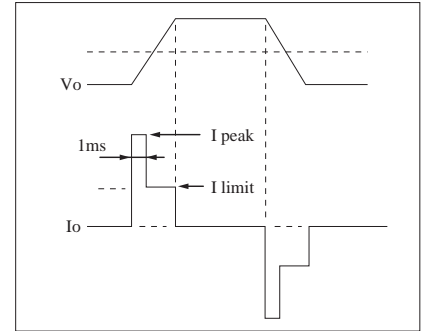



## Output range

DOP series is a bi-polar power supply which can perform four-quadrant operation. They can supply (source) and absorb (sink) current in the field of the drawing on the right.

Vo max : rated output voltage

Io max : rated output current

 AC operation range (with 50 Hz or more frequency, 50% of duty cycle and without any DC bias)

 DC operation range

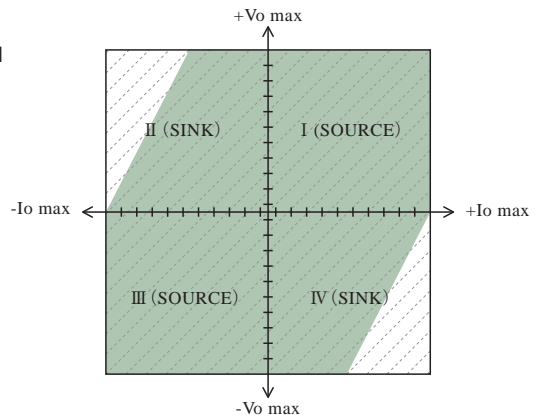

## Options

- LN** ... No protection against blackout
- LF** ... Floating ground (Withstand voltage 200 Vdc)
- LMs ( )** ... Master-slave control\*
- LPr** ... rms display
- LVc** ... Output voltage limit  
Variable from 0 to approx. 110% with the dial on the front panel
- LCc** ... Output current limit  
Variable from 0 to approx. 110% with the dial on the front panel
- L (220V)** ... 200 VAC to 240 VAC  $\pm 10\%$  single phase, 50 / 60 Hz input  
(only for 150 W models and 300 W to 350 W models)

When ordering, suffix the following option mark to the model number.

**<e.g> DOP25-12-LCcFmNPrVc (220 V) (Alphabetical and input voltage order)**

\* ( ) shall be "m" for Master unit, or "s" for Slave unit.

-LMsm for Master, -LMss for Slave.

Order required quantity for each unit. Master unit or slave unit are to be set at the factory, and if master to slave change is required after shipment, adjustment at the factory will be needed. Slave unit will also be able to operate by itself. Maximum 3 units including master unit can be connected.

## Characteristic of amplifier

### Rise time

(Stepping time): The response time is sometimes described by the rise time (as shown in the drawing on the right).

The rise time of an amplifier at a response speed of (= frequency bandwidth)  $f_c$  (Hz) is generally acquired by " $t_r \doteq 0.35 / f_c$ ."

Fall time  $t_f$  is the same as  $t_r$ .

Frequency bandwidth

: at 30 kHz or lower,  $t_r = t_f =$  around 12  $\mu$ s

: at 20 kHz or lower,  $t_r = t_f =$  around 18  $\mu$ s

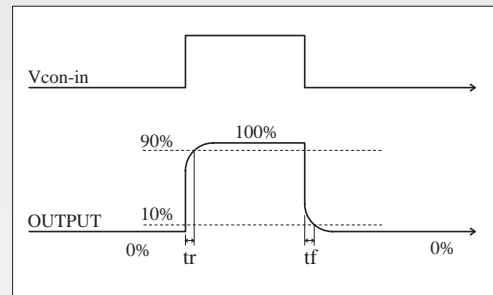

### Response speed

When accurate output waveforms are required, select a amplifier with a frequency bandwidth higher enough than the operating frequency.

In case of using sine waves, 3 to 5 times more frequency bandwidth is required, and around 10times more in case of square waves in general. Inadequate bandwidth causes not only decrease in the output amplitude but much difference between the input and output phases. Therefore operating the product while monitoring the actual output waveforms is recommended.

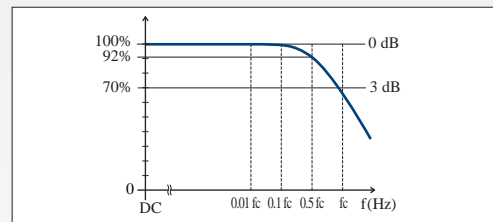

### Capacitive load

Capacitive load may cause oscillation.

In such cases, placed a power resistance in series with the output. Be careful that the frequency bandwidth is limited depending on the resistance and capacitance placed in series when capacitive load.

### Inductive load

Some inductance of inductive load may cause resonance in CC mode.

In such cases, connect a C-R series circuit between output terminals to prevent resonance.

# Functions / Dimensions inch(mm)

**A**

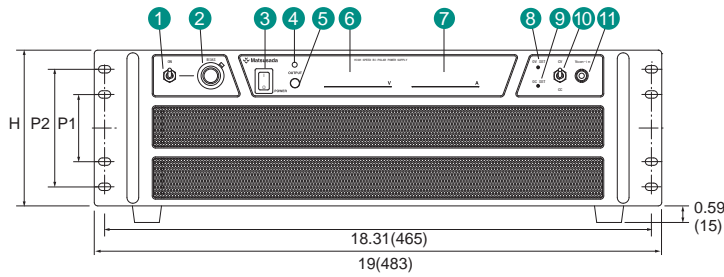

Model	H	P1	P2	D
150 W (except DOP5-30)	5.24 (133)	2.25 (57.15)	3.94 (100)	18.98 (482)
300 W, 350 W DOP5-30	5.24 (133)	2.25 (57.15)	3.94 (100)	21.65 (550)
more than 600 W	6.97 (177)	4 (101.6)	5.91 (150)	24.02 (610)

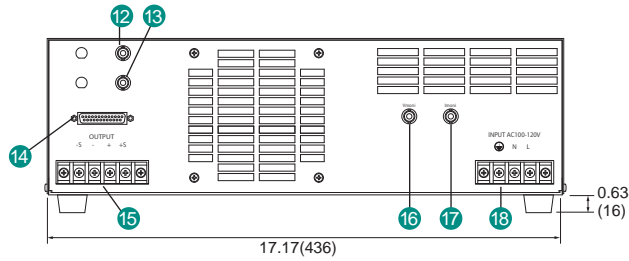

- 1 Bias ON / OFF switch
- 2 Bias setting dial
- 3 POWER ON / OFF switch
- 4 OUTPUT indication LED
- 5 OUTPUT ON / OFF switch
- 6 Voltage meter
- 7 Current meter
- 8 Output voltage limiter (option)
- 9 Output current limiter (option)
- 10 CV / CC select switch
- 11 Vcon-in terminal
- 12 Interlock
- 13 REMOTE switch ON / OFF
- 14 Connector for Master-slave (option)
- 15 OUTPUT terminal
- 16 Voltage monitor terminal
- 17 Current monitor terminal
- 18 AC input terminal

**B**

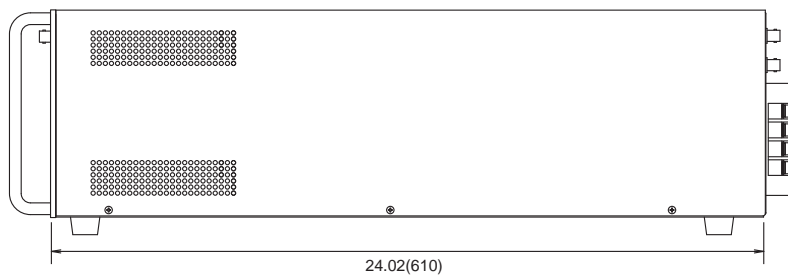
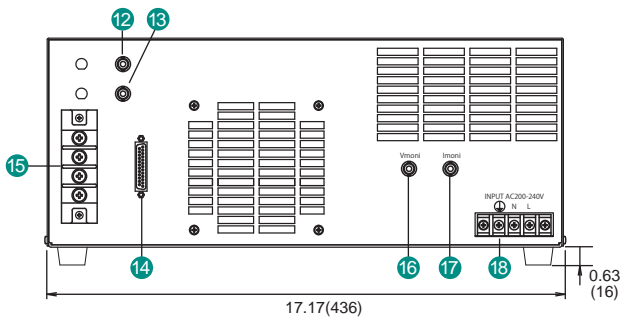
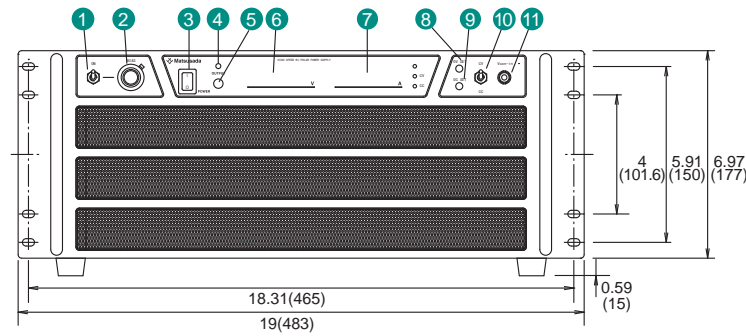

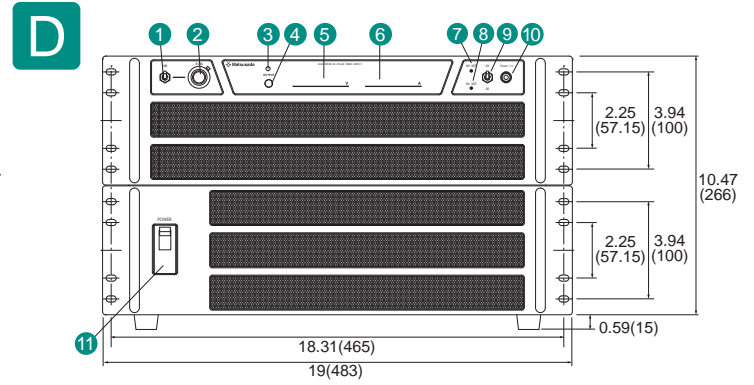
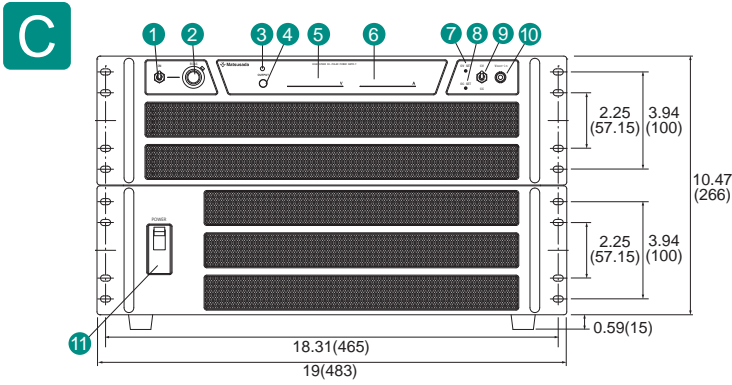

[ terminal board type ]

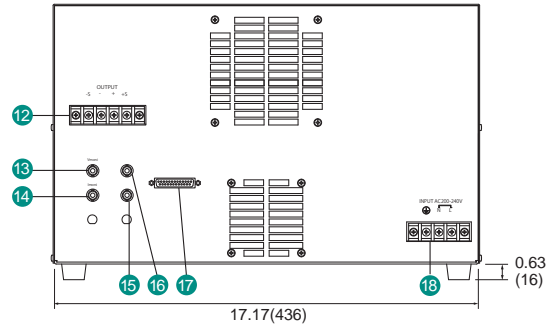
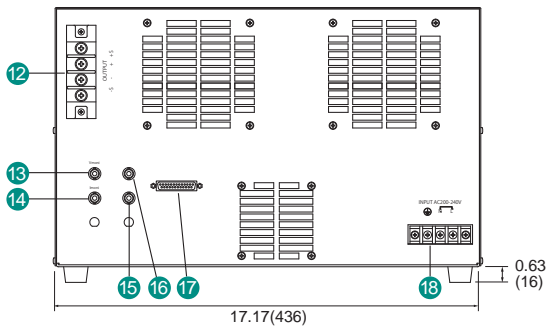

[ busbar type ]

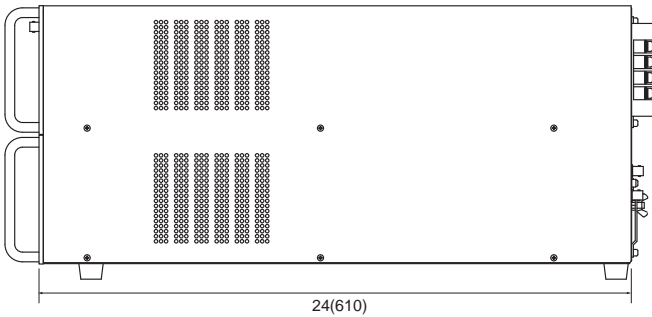
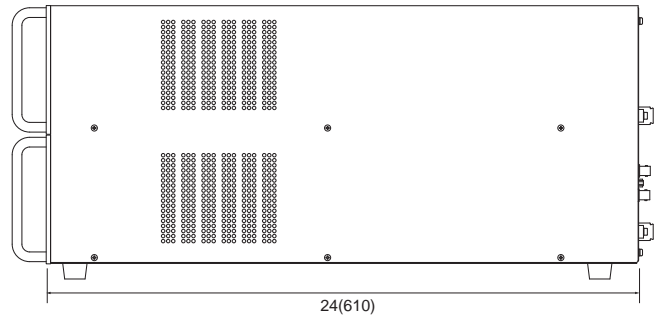
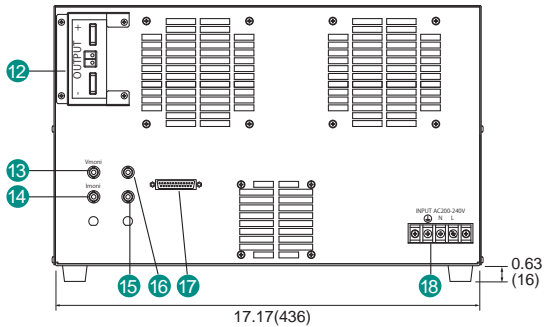

- 1 Bias ON / OFF switch
- 2 Bias setting dial
- 3 OUTPUT indication LED
- 4 OUTPUT ON / OFF switch
- 5 Voltage meter
- 6 Current meter
- 7 Output voltage limiter (option)
- 8 Output current limiter (option)
- 9 CV/CC select switch
- 10 Vcon-in terminal
- 11 POWER ON / OFF switch
- 12 OUTPUT terminal
- 13 Voltage monitor terminal
- 14 Current monitor terminal
- 15 REMOTE switch ON / OFF
- 16 Interlock
- 17 Connector for Master-slave (option)
- 18 AC input terminal

**CV/CC setting selection**

Inputting voltage via Vcon-in enables the control of output voltage V when CV control is selected and output current A when CC control is selected.

Vcon	In CV mode Output voltage	In CC mode Output current
-10 V	-Rating	-Rating
0 V	0 V	0 A
+10 V	+Rating	+Rating

**Use of BIAS**

When the "BIAS ON/OFF switch" is flipped to ON, bias can be changed with the "BIAS setting dial." Bias of the voltage can be set when CV control is selected, and that of the current can be when CC control is selected.

Scale	In CV mode Output voltage	In CC mode Output current
000 (cw)	-Rating	-Rating
500	0 V	0 A
1000 (cw)	+Rating	+Rating

