

Small Instrumentation Modules

SIM921 — AC resistance bridge

- **Accurate millikelvin thermometry**
- **microvolt/picoamp excitation**
- **Measurements from 1 mΩ to 100 MΩ**
- **Adjustable excitation (2 Hz to 60 Hz)**
- **Linearized analog output**
- **Resistance, temperature and phase**



SIM921 AC Resistance Bridge

The SIM921 AC Resistance Bridge is a precision, low-noise instrument designed for cryogenic thermometry applications. With excitation power below 100 aW, thermistors and other resistive samples can be measured at temperatures below 50 mK with negligible self-heating errors.

Measuring Resistance

The SIM921 measures resistance using a four-wire circuit, eliminating the direct effect of lead resistance on the result. Thermal EMFs and amplifier offset drifts are avoided by using an AC excitation current source. The excitation frequency can be adjusted from 2 Hz to 60 Hz, either from the front panel or over the computer interface. This flexibility allows the user to operate at a synchronous sub-harmonic of the power line frequency (such as 15 Hz/12.5 Hz) or at some incommensurate frequency, depending on requirements. Multiple SIM921s can be operated at different frequencies in the same experimental set-up without risking in-band crosstalk. Also, for very high impedance measurements, the

variable frequency makes it possible to probe any capacitive effects in the resistance result. Excitations are sinusoidal, eliminating the high-frequency harmonic content associated with square wave excitations.

The actual determination of resistance is achieved ratiometrically, passing the selected excitation current through both an internal, high-stability reference resistor as well as the user's device under measurement. An internal auto-cal is available to calibrate the two arms of the ratio readout for greater accuracy.

Excitation

Two excitation modes, constant current and constant voltage, are available with the SIM921. Most low-temperature thermometry applications use negative temperature-coefficient resistors. The constant voltage mode has the benefit of decreasing the power dissipated in the thermometer as the temperature drops. In this mode, the SIM921 servos the applied AC excitation to maintain the selected voltage across the user's resistor.

SIM921 AC Resistance Bridge

Constant current mode is appropriate when measuring small resistances, such as characterizing superconducting transitions. In constant current mode, the internal reference resistor is used as the input to the servo, giving a constant current equal to the selected voltage divided by half the resistance range (for instance, 100 μV on the 20 $\text{k}\Omega$ range gives 10 nA rms excitation current).

Phase Sensitive Detection

A pair of dual-phase, sinusoidal AC demodulators in the SIM921 provide excellent signal-to-noise ratio in the most difficult test conditions. Further, dual-phase demodulation enables resistance and phase-shift measurements. Large phase shifts can warn the user of excessive lead reactance. Selectable post-demodulation time constants from 300 ms to 300 s give you complete control over the trade-off between measurement response time and ultimate resolution.

Autorange

Two autoranging features are provided on the SIM921. The “display” autorange feature shifts the decimal point (and possibly the units indicator) in the display to maximize resolution. Holding the Autorange button initiates a “gain” autorange cycle, which peaks up the internal amplifier gains to optimize the signal-to-noise ratio. Under all cases, the excitation settings remain unchanged by the instrument, ensuring the user complete control over measurement conditions in an experiment.

Thermometry

The SIM921 is compatible with all resistive sensors including NTC sensors (germanium, carbon glass, carbon-composition, ruthenium oxide, etc.), and PTC sensors (rhodium-iron RTD, platinum RTD, etc.). Up to four user-calibration curves (ohm to kelvin), with 200 points of data each, can be uploaded to the instrument’s non-volatile memory via the computer interface.

Output

In addition to the display output and computer interface, an analog output provides a DC voltage proportional to either resistance or temperature. The user has full control over the scale (V/K or V/Ω) and offset (K or Ω) of this output.

Temperature Control

The analog output signal is well suited to connect with the SIM960 Analog PID Controller. This combination of modules provides a flexible and cost-effective temperature control solution.

Front-Panel Display

The primary readout is an easy-to-read 5½-digit LED display (statically driven for low noise). This display can show measured value (resistance or temperature), value minus offset, phase shift, offset, excitation frequency, analog output scale, and cal-curve. Separate bar-style displays indicate the

resistance range, excitation, and output time constant, as well as excitation mode (current or voltage) and autorange setting.

Interfaces

All instrument parameters can be controlled and displayed on the front panel or set and queried over the computer interface. The analog DC output is available on a front-panel BNC connector.

The rear panel has a standard 9-pin D-sub connector for the sensor. Power and serial communications are via the 15-pin D-sub connector which mates with the SIM900 mainframe. Stand-alone operation of the SIM921 is possible by providing $\pm 15\text{ V}$ and $+5\text{ V}$ power directly on the 15-pin connector.

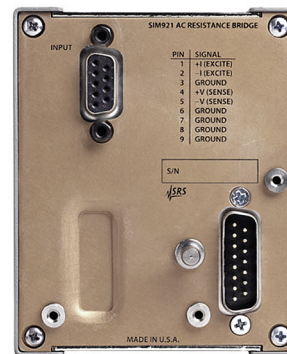

SIM921 rear panel

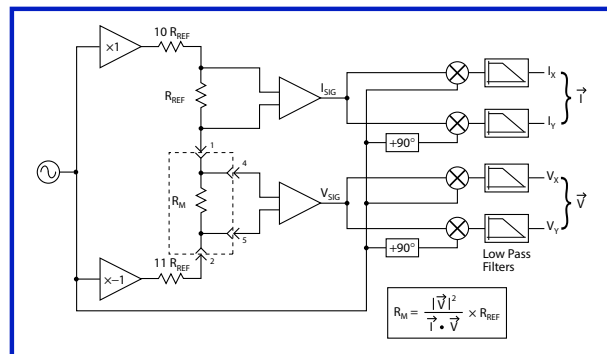

SIM921 Block Diagram

The figure shows the overall architecture of the SIM921 AC Resistance Bridge. A sinusoidal excitation is applied to the half-bridge formed by the internal reference resistor R_{REF} and the external user’s resistor under measurement R_{M} (dashed box). Two parallel, low-noise differential amplifiers measure the AC voltage across R_{REF} and R_{M} via kelvin leads. The results, I_{SIG} and V_{SIG} , are sent to separate dual-phase demodulators to produce the vector quantities I and V . Finally, the in-phase component of the current is divided into the measured voltage to determine the value of R_{M} .

Measurement

Measurement type	4 wire AC bridge
Number of inputs	1
Resistance range	1 mΩ to 100 MΩ
Time constant	0.3 s to 300 s
Reading rate	Two updates per second
Demodulator resolution	32-bit
Resolution	see table
Accuracy (% reading + % range)	
2 Ω to 200 kΩ	±(0.05 % + 0.05 %) at an excitation of ≥30 μV and ≥3 nA
200 mΩ to 2 MΩ	±(0.15 % + 0.15 %) at an excitation of ≥300 pA
Stability	
With auto-cal	(±0.001 % of reading)/°C
Without auto-cal	(±0.02 % of reading)/°C
Max. lead resistance	100 Ω + 25 % range
Input impedance	>10 GΩ (typ.)
Source	
Type	Sinusoid, constant current or voltage
Source frequency	2 Hz to 60 Hz
Excitation	3 μV to 30 mV, 10 mA (max.)
Max. DC current	<3 μV/range

Thermometry

Sensors supported	All negative and positive temperature coefficient resistive sensors
-------------------	---

Resolution

Resolution is given in the table below. Upper values give excitation current, while lower values are typical rms resistance noise measured at 50 % full scale on a room temperature resistor with a three second output time constant.

Range	Excitation								
	30 mV	10 mV	3 mV	1 mV	300 μV	100 μV	30 μV	10 μV	3 μV
20 mΩ	N/A	N/A	N/A	N/A	N/A	10 mA	3 mA	1 mA	300 μA
						44 μΩ	130 μΩ	510 μΩ	1.5 mΩ
200 mΩ	N/A	N/A	N/A	10 mA	3 mA	1 mA	300 μA	100 μA	30 μA
				8.9 μΩ	12 μΩ	32 μΩ	120 μΩ	590 μΩ	1.4 mΩ
2 Ω	N/A	10 mA	3 mA	1 mA	300 μA	100 μA	30 μA	10 μA	3 μA
		4.3 μΩ	5.5 μΩ	7.9 μΩ	23 μΩ	70 μΩ	220 μΩ	730 μΩ	1.8 mΩ
20 Ω	3 mA	3 mA	300 μA	100 μA	30 μA	10 μA	3 μA	1 μA	300 nA
	20 μΩ	21 μΩ	33 μΩ	41 μΩ	100 μΩ	390 μΩ	1.7 mΩ	4.1 mΩ	10 mΩ
200 Ω	300 μA	100 μA	30 μA	10 μA	3 μA	1 μA	300 nA	100 nA	30 nA
	200 μΩ	200 μΩ	370 μΩ	430 μΩ	1.1 mΩ	2.8 mΩ	9.7 mΩ	25 mΩ	120 mΩ
2 kΩ	30 μA	10 μA	3 μA	1 μA	300 nA	100 nA	30 nA	10 nA	3 nA
	2.0 mΩ	2.0 mΩ	2.9 mΩ	4.0 mΩ	12 mΩ	40 mΩ	120 mΩ	300 mΩ	900 mΩ
20 kΩ	3 μA	1 μA	300 nA	100 nA	30 nA	10 nA	3 nA	1 nA	300 pA
	20 mΩ	25 mΩ	31 mΩ	56 mΩ	200 mΩ	640 mΩ	2.4 Ω	5.3 Ω	23 Ω
200 kΩ	300 nA	100 nA	30 nA	10 nA	3 nA	1 nA	300 pA	100 pA	30 pA
	250 mΩ	350 mΩ	640 mΩ	1.4 Ω	4.5 Ω	16 Ω	47 Ω	150 Ω	710 Ω
2 MΩ	30 nA	10 nA	3 nA	1 nA	300 pA	100 pA	30 pA	10 pA	3 pA
	3.4 Ω	5.9 Ω	16 Ω	46 Ω	190 Ω	480 Ω	1.7 kΩ	5.4 kΩ	15 kΩ
20 MΩ	3 nA	1 nA	300 pA	100 pA	30 pA	10 pA	3 pA	1 pA	300 fA
	50 Ω	190 Ω	540 Ω	1.1 kΩ	5.4 kΩ	12 kΩ	56 kΩ	180 kΩ	750 kΩ

Temperature units	K, mK
Low temperature	50 mK, sensor dependent
Sensor cal. curves	4 curves of 200 points each

Analog Output

Range	±10 VDC
Resolution	300 μV
Accuracy	1 mV

General

Operating temperature	0 °C to 40 °C, non-condensing
Interface	Serial via SIM interface
Connectors	
Sensor	DB9 (female)
SIM	DB15 (male) SIM interface
Analog out	BNC (front)
Power	Powered by SIM900 Mainframe, or by user-provided DC power supply (±15 V and +5 V)
Dimensions	3.0" × 3.6" × 7.0" (WHD)
Weight	2.3 lbs.
Warranty	One year parts and labor on defects in materials and workmanship

Ordering Information

SIM921 AC resistance bridge